



FOR **T**EX[®]

Textured Cladding Systems

FORTEX[®]

Fortex is a range of innovative cladding products that couple the benefits of low maintenance PVC with a choice of two attractive finishes. An authentic embossed wood effect or a stippled render finish available in a wide range of subtle colours.

Durable

The Fortex cladding range is manufactured using Freefoam's environmentally friendly lead free formulation and is guaranteed to stand the test of time. The range qualifies for a 10 year guarantee* and is backed by Freefoam's unique Colormax technology.

Light and easy to install

Fortex cladding panels are designed to make storing, handling and fitting the range quick and easy. With the Weatherboard cladding weighing just 3.15kg per 5 metre board it is 4 times lighter than a comparable fibre cement board.

The Fortex range includes a comprehensive suite of accessories to ensure easy, straightforward installation in all situations and offers a neat and professional finish.



A+ Environmental Rating



No Painting Required

External Insulation Concept



- 1 Substrate
- 2 Semi-Solid Insulation
- 3 Timber Studs
- 4 Timber Counter Battens
- 5 Breather Membrane
- 6 Timber Cladding Battens
- 7 Fortex Cladding

A+ Rated Cladding

With higher fuel costs and the need to reduce carbon emissions exterior cladding offers the ideal solution. Fortex is designed for use on all types of exteriors including brick, masonry and concrete. When fitted with standard insulation materials the Building Research Establishment's (BRE) Green Guide to Specification has given PVC cladding an A+ rating.

Front Cover: FCF170E - White
Below: FCF170E - Colonial Blue/White

*Please see www.myfreefoam.com for guarantee terms and conditions

**FCF170E
WEATHERBOARD CLADDING**

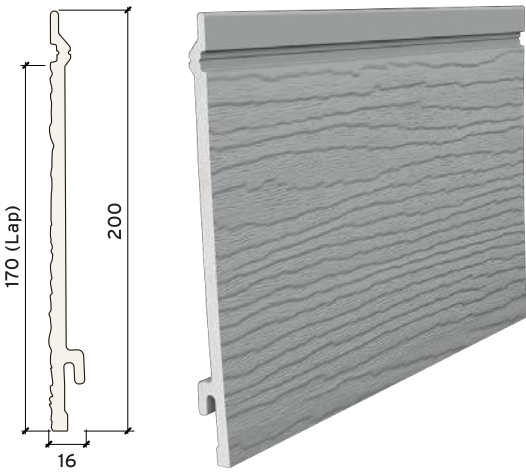

Butt Joint - (FCF209E)



White Pale Gold Sand Pale Blue



Storm Grey Colonial Blue Argyl Brown

**FCD333E
PRO DOUBLE PLANK SHIPLAP CLADDING**

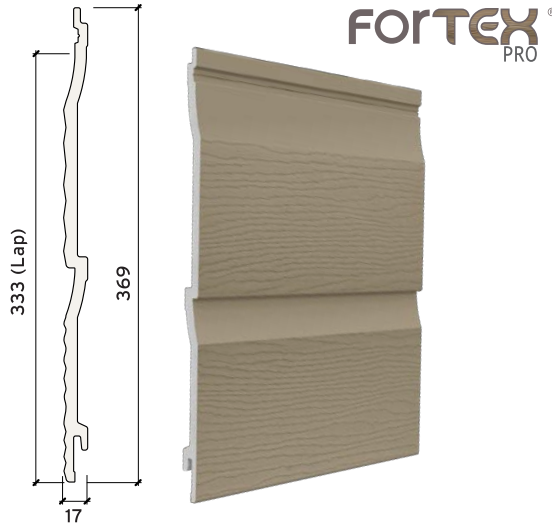

Butt Joint - (FCD210E)



White Pale Gold Sand Misty Grey



Storm Grey Colonial Blue Cappuccino Argyl Brown Slate Grey

**FCD300E
DOUBLE PLANK SHIPLAP CLADDING**

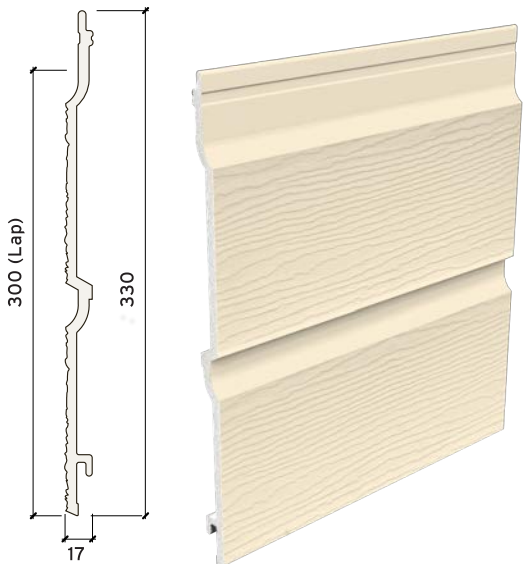

Butt Joint - (FCD209E)



White Pale Gold Sand

**FCP250E
FLAT PANEL CLADDING**

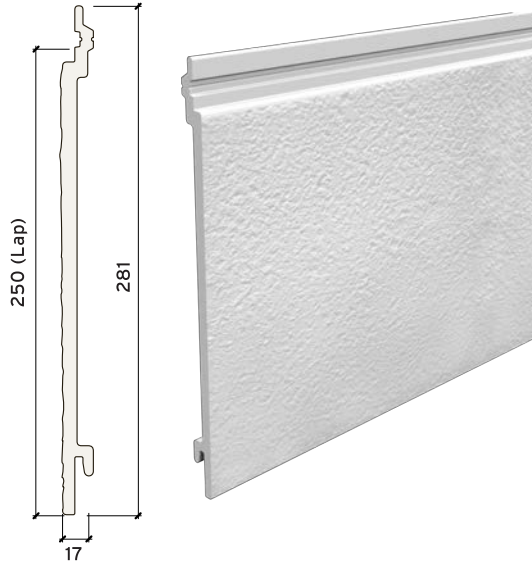

Butt Joint - (FCP209E)



White Sand

Trim Range

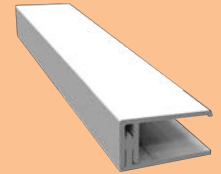

Internal Edge Trim
(FC301E3)

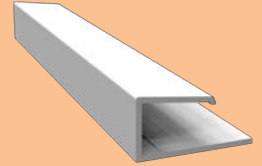

Universal Edge Trim
(FC302E3)

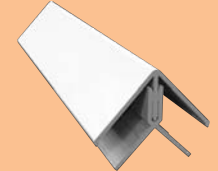

External Corner Trim
(FC304E3)

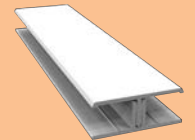

2 Part 'H' Trim
(FC315E3)

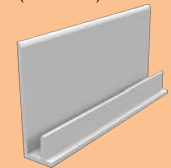

Starter Trim
(FCF2123)

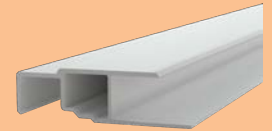

Multifunction Trim
(FCD220E3)

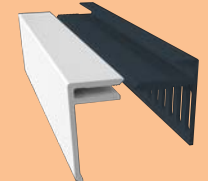

Vented Trim & Cover
FC311E3 = 25mm / FC314E3 = 35mm



Vented Starter
(FC3123 = 25mm / FC3133 = 35mm)

2 Part Reveal Liner
(FC319E3)



Reveal Liner Edge/Extension
(FC318E3)

Product colours shown in this brochure are for availability identification only. Please see colour swatch or product samples for exact colour representations. All specifications, dimensions, descriptions and illustrations contained in any Freefoam sales literature, quotation, pricelist or other advertisement matter are intended merely to present a general idea of the goods we sell.

We reserve the right from time to time to make changes which are required to comply with any applicable safety or statutory requirements or which do not manually affect the quality or fitness for purpose of the goods you purchase from us.

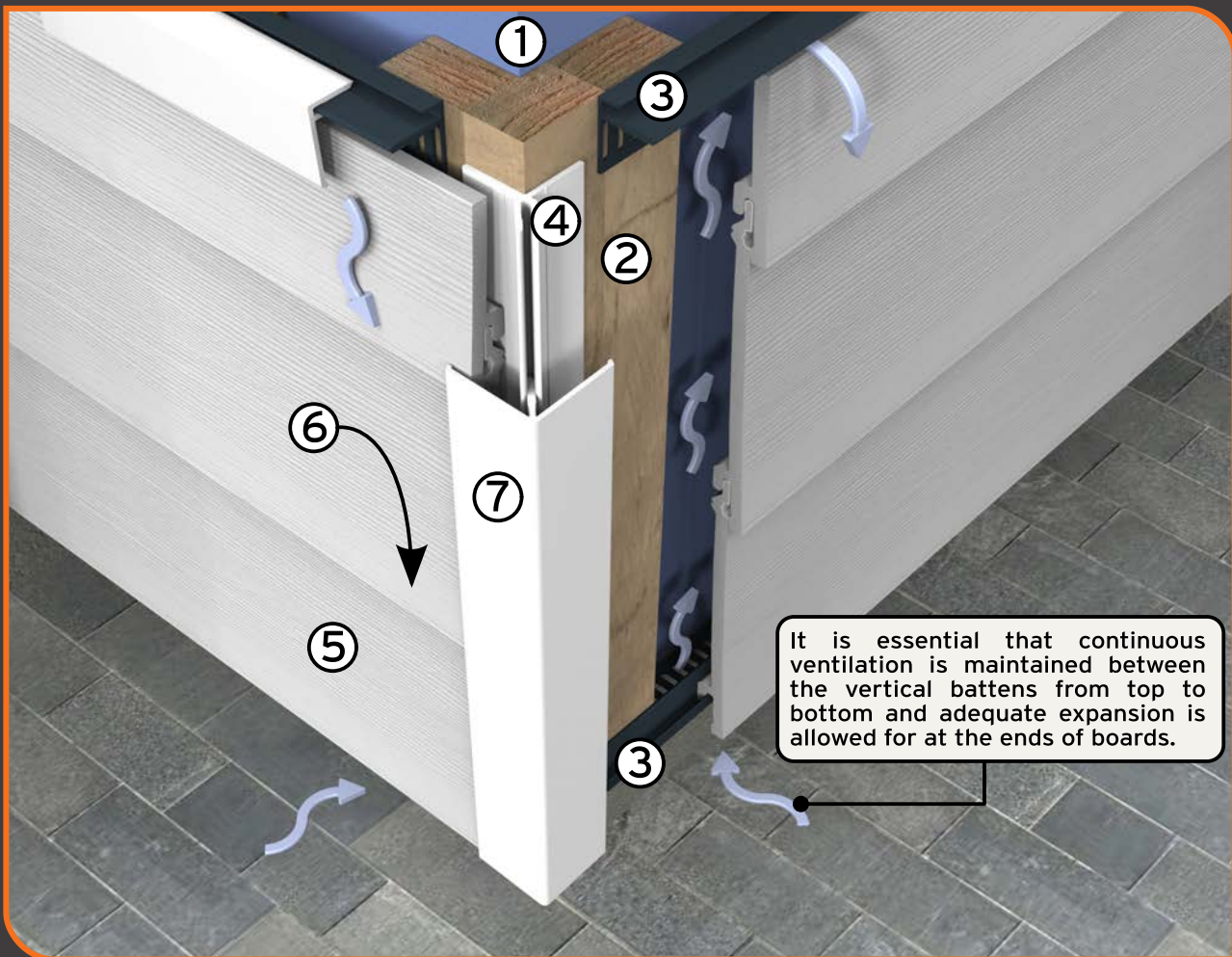

Typical Installation Sequence

- ① Fix a suitable breather membrane to substrate in accordance with manufacturer's recommendations.
- ② Fix vertical battens* to substrate at 400mm c/c. Start 200mm from the ground.
*Use 25mm x 50mm battens for light colours; White, Pale Gold, Misty Grey, Sand & Pale Blue.
*Use 35mm x 50mm battens for dark colours; Argyl Brown, Cappuccino, Colonial Blue, Storm Grey & Slate Grey.
- ③ Fix ventilated starter/trim along base and top of area to be clad. Use FC3123 for 25mm battens & FC3133 for 35mm battens
- ④ Fix Single Part Trims and/or first part of Two Part Edge, Corner and 'H' Trims as necessary. Do not cut second parts of trim to length yet.
- ⑤ Fit first Cladding Plank to Vented Starter Trim and screw fix top to cladding batten. Where necessary join the ends of boards using a compatible Butt Joint or 'H' Trim.
- ⑥ Interlock next Cladding Plank to the Plank below and screw fix top to cladding batten, repeating the process until the entire area to be clad is covered.
- ⑦ Cut second parts of 2 part trims to length and clip in place.

	FCF170E	FCD333E	FCD300E	FCP250E
FC301E3	✓	✓	✓	✓
FC302E3	✓	✓	✓	✓
FC304E3	✓	✓	✓	✓
FC315E3	✓	✓	✓	✓
FCF2123	✓	✓	✓	✓
FC311E3	✓	✓	✓	✓
FC3123	✓	✓	✓	✓
FC3133	✓	✓	✓	✓
FC314E3	✓	✓	✓	✓
FCD220E3	✓	✓	✓	✓
FC318E3	✓	✓	✓	✓
FC319E3	✓	✓	✓	✓
FCF209E	✓			
FCD210E		✓		
FCD209E			✓	
FCP209E				✓

Board Length = 5000mm
Trim length = 3000mm

Cladding Type	Cladding Coverage
FCD300E Double Plank	1.5m ² /Length
FCF170E Weatherboard	0.85m ² /Length
FCP250E Flat Panel	1.25m ² /Length
FCD333E Double Plank	1.65m ² /Length



Typical Starter

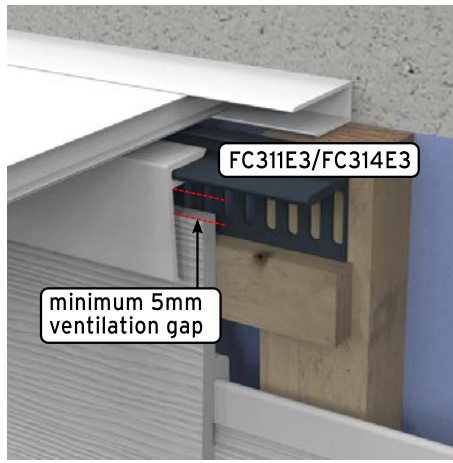

Typical Top/Closer

General Notes:

Always allow Thermal Expansion gaps between trims and at ends of cladding boards.

Allow Ventilation at both the top and the bottom of installations as indicated.

Always Install in accordance with good building practice and relevant regulatory guidance.

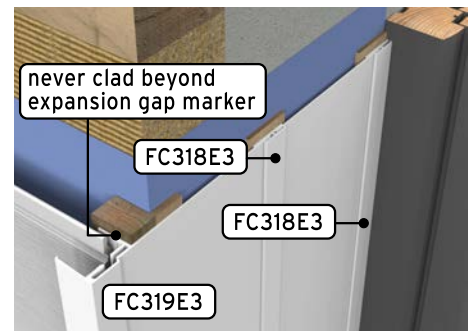
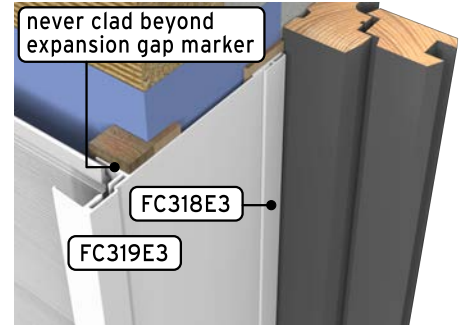

Typical Window Reveals

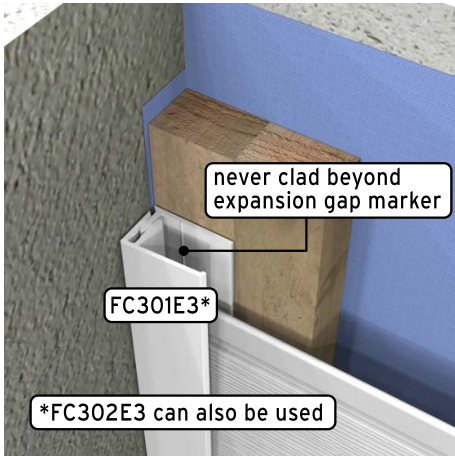

Typical 2 Part Edge

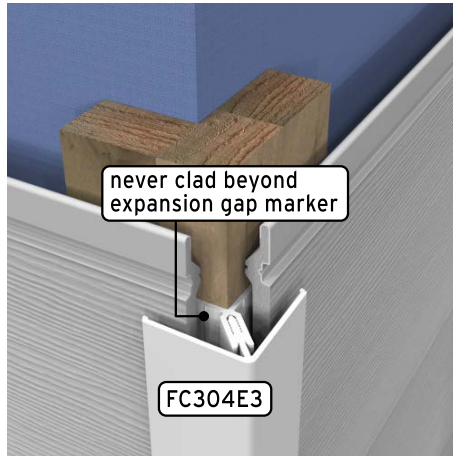

Typical 2 Part External Corner

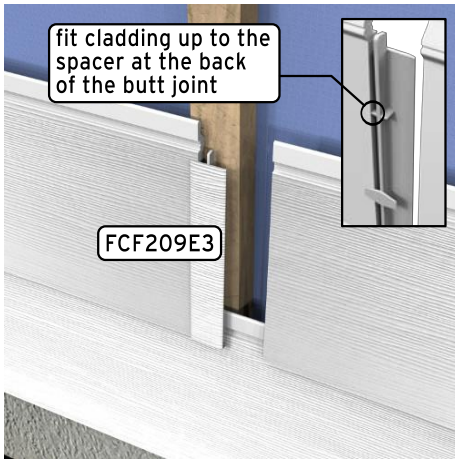

Typical Butt Joint

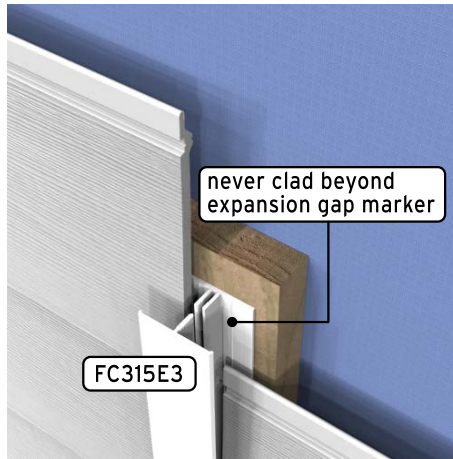

Typical 2 Part 'H' Trim

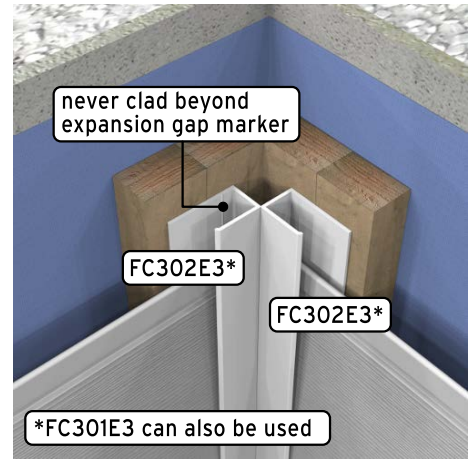

Typical Internal Corner



Typical Edge Detail - Multifunction Trim

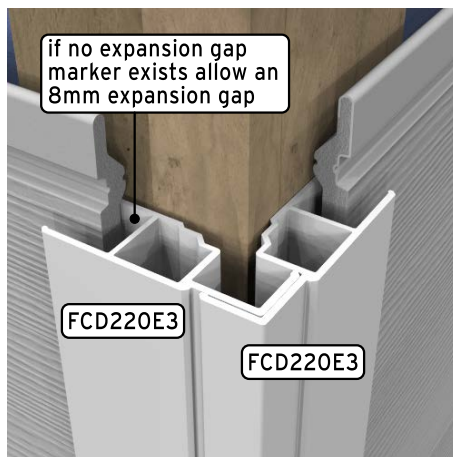

Typical External Corner - Multifunction Trim

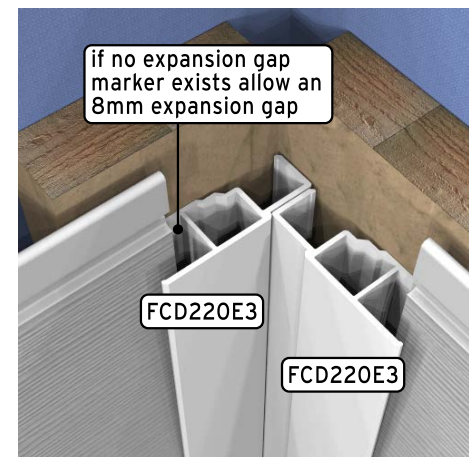

Typical Internal Corner - Multifunction Trim

Technical and Specification Information

Freefoam cladding products are produced from cellular PVC. A co-extrusion process enables them to be covered with a layer of PVC resistant to UV rays and discolouration. An additional embossing process gives the Fortex products their textured effect.

Material

Cellular PVC
UV Resistant coloured co-extruded skin
Density: 510kg/m³
Expansion coefficient: $5 \times 10^{-5} / ^\circ\text{C}$

Tolerances

Width: +/- 0.5mm
Length: +/-5mm
Thickness: +/- 1mm

Weight per 5m board

FCD300E	6KG
FCF170E	3.15KG
FCP250E	5.50KG
FCD333E	7.85KG

Fire Resistance

Freefoam cellular PVC cladding conforms to the following classification:
D-s3, d2/AHM

Thermal Insulation

Freefoam profiles, due to the cellular foam core composition, have a general thermal conductivity rate of 0.06 and 0.1 W/mK (depending on the configuration and profile thickness). This represents a performance superior to timber or other natural products

COLORMAXTM

technology

Freefoam's innovative ColormaxTM technology provides ground-breaking colour variety, colour matching and colourfastness. By using a proprietary formulation that contains a unique selection of stabilisers and pigments specially chosen for their high colourfast properties, Freefoam can confidently offer a wide range of colours.

As a result specifiers, architects, contractors and homeowners can now put their individual mark on their house or project with ease.



www.freefoam.com
sales@freefoam.com

July 2016

